

DIVERTER VALVE

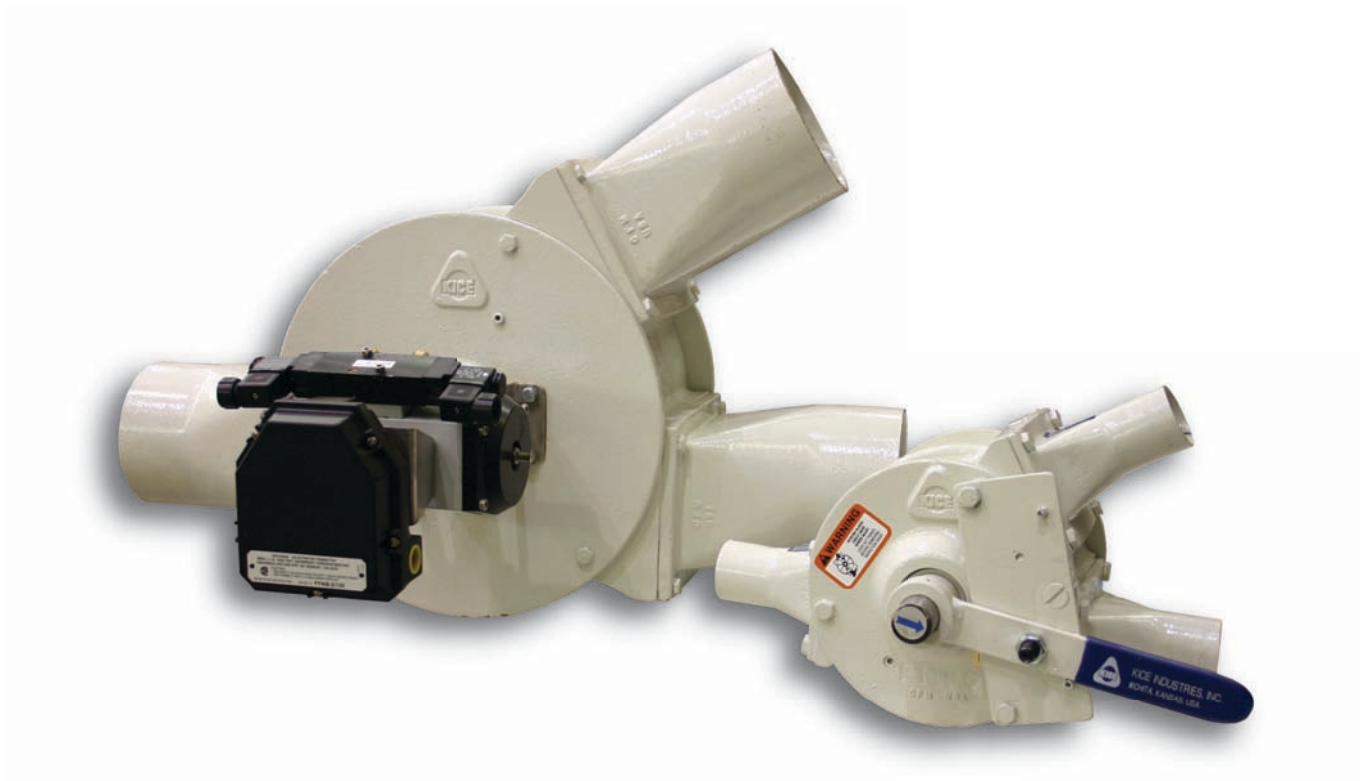

OPERATOR'S MANUAL

Kice Industries, Inc.
5500 Mill Heights Drive
Wichita, KS 67219
P: 316.744.7151 F: 316.744.7355

1. INTRODUCTION

CONGRATULATIONS

When you purchased your Kice heavy duty two way or three way diverter valve or bin fill valve, you bought a valve that has proven its reliability based on hundreds of installations and years of dependable service.

We are proud of our products and the people at Kice who build them. At Kice, the manufacturing process starts in our own foundry by following the construction standards and manufacturing techniques that have proven superior over the last 60 years.

The results of our development work and input from users have resulted in the present design of the Kice diverter valves.

This owner's manual is intended as a guide for proper installation, operating and maintenance to keep your Kice diverter valve operating safely and efficiently on the job. Service and spare parts information is also included for your benefit.

Sincerely,

Thomas F. Kice
President & C.E.O.
Kice Industries, Inc.

Warranty

The Company warrants the equipment manufactured by the Company to be free of defects in material and workmanship for a period of one (1) year from the date of shipment. Kice agrees to repair or replace, at its option, any parts found to be defective in the opinion of the Company. Kice is not liable for any costs in connection with the removal, shipment or reinstallation of said parts. This warranty does not apply to abrasion, corrosion, erosion, abuse or misuse of the product. Assistance by Kice in system layout or selecting equipment does not imply Kice's responsibility.

Buyer agrees to look to the warranty, if any, of the manufacturer or supplier of equipment manufactured by others and supplied by Kice for any alleged defects in such equipment, and for any damages or injuries caused thereby or as a result thereof. Where work is made to measurements or specifications furnished by the Buyer, Kice does not assume any responsibility for the accuracy of Buyer's specifications. Kice will not assume responsibility for alteration or repairs unless the same are made with the written consent and approval of Kice.

PURCHASER SHALL BE RESPONSIBLE FOR COMPLIANCE WITH ELECTRICAL MANUFACTURER'S RECOMMENDATIONS, UNDERWRITERS CODE AND ALL SAFETY PRECAUTIONS.

Kice extends no other warranty for any of its products other than the above express warranty, and there are not other warranties, express or implied, including warranties of merchantability, fitness for a particular purpose or otherwise which extend beyond the above limited express warranty. Kice and its dealers shall not in any event be liable for consequential or incidental damages, and the terms and conditions stated herein provides Buyer's sole and exclusive remedy. Any actions for breach of this agreement or warranty must be commenced within one year after the cause of action has occurred.

TABLE OF CONTENTS

1. INTRODUCTION	2
2. GENERAL INFORMATION	4
3. SAFETY PRECAUTIONS	6
4. GENERAL RECEIVING, HANDLING AND INSTALLATION	8
5. OPERATION AND START-UP PROCEDURE	10
6. DIVERTER VALVE MAINTENANCE AND SERVICE	12
7. TROUBLESHOOTING	16
8. ILLUSTRATED PARTS LIST	19
9. WIRING SCHEMATICS	23

IMPORTANT

Write down the MODEL and SERIAL NUMBER of the Kice valve, along with the information for the auxiliary equipment (i.e., operators, valves, position switch, etc.).

For additional information, application assistance or special service, you should contact the factory. We will need to know the MODEL and SERIAL NUMBER of your Kice diverter valve. For ready reference, please record this information and the date of delivery or installation on the lines below. See the General Information section for the location of the model and serial number.

Model:

Serial Number:

Date of delivery or installation:

2. GENERAL INFORMATION

The purpose of this manual is to assist owners and operators in maintaining and operating the Kice diverter valve or bin fill valve. Please read it carefully; the information and instructions furnished can help you achieve years of dependable performance. Separate manuals may be required for the auxiliary equipment that make up the controls for the valve, such as, the solenoid operated 4-way valve or the position switch. They contain additional information that may not be repeated in this manual. You are urged to read all manuals before attempting any operation or repair of the equipment in the system. If these manuals are not included in your owner's packet, contact our customer service department.

USING THIS MANUAL

General operation, adjustment and maintenance guidelines are outlined for owners and operators of the Kice diverter valve or bin fill valve. Operating conditions vary considerably and cannot be addressed individually. Through experience, however, operators should have no difficulty in developing good operating, safety and monitoring skills.

The term "disconnect and lockout" as used in this manual means that power (electric and/or air) to the equipment has been disconnected through the use of a padlockable, manual power cutoff, or power lockout switch.

Directions used in this manual, for example RIGHT or LEFT, CLOCKWISE, or COUNTERCLOCKWISE, refer to directions when facing the controls mounted on the side of the diverter valve with the inlet to the left and the outlets to the right.

Photographs and illustrations were current at the time of printing, but subsequent production changes may cause your Kice diverter valve to vary slightly in detail. Kice Industries, Inc., reserves the right to redesign and change the equipment as deemed necessary, without notification. If a change has been made to your Kice diverter valve that is not reflected in this owner's manual or the illustrated parts list, write or call Kice Industries, Inc., for current information and parts.

MODEL AND SERIAL NUMBER

The model of the diverter valve and bin fill valve and the serial number can be found on the stamped metal identification plate located on the end plate of the valve (see Figure 1).



Figure 1

GENERAL INFORMATION CONTINUED

KICE DIVERTER VALVE PARTS AND SERVICE

Use original Kice diverter valve replacement parts only. These parts are available from Kice Industries, Inc. To obtain prompt, efficient service, always provide the following information when ordering parts:

Correct part description and number, as given in the Illustrated Parts Lists section of this manual

Correct model number

Correct serial number

For assistance in service or ordering parts, contact the customer service department:

Kice Industries, Inc.
5500 Mill Heights Drive
Wichita, KS 67219-2358
Phone: 316-744-7151 Fax: 316-744-7355

IMPORTANT: Any unauthorized modification, alteration, or use of non-approved attachments or drive units voids the warranty and releases Kice Industries, Inc., from any liability arising from subsequent use of this equipment. Each Kice diverter valve is designed to be used in a specific type of system. Using the Kice diverter valve for a purpose other than that for which it was designed could result in personal injury, as well as, product or property damage.

FOR PURCHASED PARTS AND SERVICE

Purchased items (such as, position switches, solenoid valves, pneumatic cylinders, pneumatic rotary actuators, and electric actuators) are covered by the manufacturer's warranty. If there is a problem with a purchased item, it may be quicker to check with the local supplier or service representative.

3. SAFETY PRECAUTIONS



Figure 2

This safety alert symbol is used on equipment, safety decals and in manuals to call your attention to an important safety message warning you of possible danger to your personal safety. When you see this symbol (Figure 2), be alert; your personal safety or the safety of other persons is involved. Follow the instructions in the safety message.

HAZARD LEVELS



DANGER (RED) – Danger is used to indicate the presence of a hazard that **WILL** cause **SEVERE** personal injury, death, or substantial property damage if the warning is ignored.



WARNING (ORANGE) – Warning is used to indicate the presence of a hazard that **CAN** cause **SEVERE** personal injury, death, or substantial property damage if the warning is ignored.



CAUTION (YELLOW) – Caution is used to indicate the presence of a hazard that **WILL** or **CAN** cause **MINOR** personal injury or property damage if the warning is ignored.



WARNING: All owners and operators should read this manual, or be instructed in safe operating and maintenance procedures, before attempting to uncrate, install, operate, adjust, or service this equipment.

SAFETY DECALS

The safety decals on the diverter valve should not be removed, covered over, painted, or otherwise become illegible. If this occurs, the decals should be replaced immediately. Contact our customer service department for replacements.

SAFETY PRECAUTIONS CONTINUED

ADDITIONAL SAFETY PRECAUTIONS:

- Do not attempt to install, connect power to, operate or service your new diverter valve without proper instruction and until you have been thoroughly trained in its use by your employer.
- Do not attempt to work on, clean or service the diverter valve, or open or remove any protective cover, guard, grate or maintenance panel until the POWER has been turned off and LOCKED OUT.
- Do not manually override or electrically bypass any protective device.
- Do not connect power to or operate the diverter valve unless all moving parts are covered and all covers, guards, grates and maintenance panels are in place and securely fastened.
- Do not abuse, overload, mistreat or misuse the diverter valve or attempt to operate the diverter valve and bin fill valve if it is in need of service, lubrication, maintenance or repair.
- Never place any part of your body in or near rotating members or moving parts of the diverter valve or air cylinder.
- The diverter valve may have factory supplied guards for rotating components. Moving parts must be completely enclosed before connecting power and before operation.
- If the diverter valve is equipped with a maintenance panel or access door incorporating a Protective Interlocking Limit Switch (PLS), the PLS must be interlocked with all electrical controls so that all motors or powered devices on the unit will be de-energized if any protective cover, guard, grate or maintenance panel is open or removed. Never attempt to manually override or electrically bypass a safety device. The interlock function of the PLS must be tested and logged daily by supervisory personnel.
- Many diverter valves are installed and wired to divert automatically or be controlled from remote locations. Keep clear of all moving parts on industrial equipment at all times.
- Diverter valves must be equipped with a properly functioning Protective Interlocking Electrical Control Switch (PCS), a Padlockable Manual Power Lockout Switch, and with the other basic safety equipment listed above. On-off, interlock and padlock functions of the PCS must be tested and logged daily by supervisory personnel.
- It is the owner's and the employer's responsibility to adequately train the employee-operator in the proper and safe use of the equipment. Written safety programs and formal instruction are essential. All new employees must be made aware of company policies and operating rules, especially the established safety and health procedures. Refresher training of experienced employees in the potential hazards of the job is important. Up-to-date training records must be maintained at the job site.
- Special attention must be devoted to outside contractors engaged to enter and perform work on equipment or in the workplace. Special care must be exercised to insure all such personnel are fully informed of the potential hazards and follow plant rules – with special emphasis on explosion proof electrical tools and cutting or welding in unsafe environments.
- Keep the workplace cleaned up and free of dirt and dust at all times. Do not attempt to work on slippery or unsafe ladders or work platforms when maintenance or repair work is being performed on the diverter valve.
- Do not climb on ladders or work on platforms unless maximum load rating is posted. Do not exceed maximum load ratings when installing or servicing the diverter valve.
- Never allow any kind of metal or other foreign objects to enter a diverter valve while in operation.
- All diverter valve inlet and discharge openings must be completely connected to the piping system to prevent human access while the equipment is operating, and must remain connected until POWER IS TURNED OFF AND LOCKED OUT. Keep away from the moving parts of the diverter valve during operation.
- Operate safely at all times. Use personal protective equipment when and where appropriate, such as hard hats, helmets, gloves, earplugs, and eye protection devices. Keep personal protective equipment in good repair and convenient to the operator.
- Actuation components must be inspected and adjusted after transportation and periodically as required by operating conditions. Check clevis pins, lock nuts, bolts holding the mounting bracket to the valve, lever arm on the position switch, air hoses to the high pressure 4-way valve, coupling alignment, set screws and keys, as appropriate to job conditions.
- High voltage and rotating parts can cause serious or fatal injury. Only qualified, trained, and experienced personnel should perform installation, operation and maintenance of electrical machinery. Make sure that the diverter valve is effectively grounded in accordance with OSHA safety and health standards, the National Electrical Code and local codes.
- Never stand under any kind of hoist or lifting mechanism, whether or not it is loaded or in operation. Never stand under or near a diverter valve or component when it is being lifted.
- Qualified personnel, before each use, must carefully inspect all lifting devices. Never use a lifting device to transport equipment. Never use a lifting device that is damaged, deteriorated, or in any way in need of repair.
- All protective covers, guards, grates, maintenance panels, switches and warning decals must be kept in place and in good repair. Any equipment with a damaged, malfunctioning, defective, or missing protective device must be taken out of service until the protective device can be repaired or replaced.
- Any device powered by air or hydraulic pressure must be equipped with a properly functioning Padlockable Manual Pressure Lockout and Internal Pressure Relief Valve (PRV).
- Any diverter valve that is used in the processing of explosive materials in hazardous environments requires an evaluation on the part of the user and operator of proper and adequate monitoring equipment, dust control, explosion relief venting, and electrical equipment enclosures. Do not use your equipment in hazardous environments unless it has been properly equipped for the hazard.
- It is ultimately the operator's responsibility to implement the above listed precautions and insure proper equipment use, maintenance and lubrication. Keep these instructions and a list of warnings with your machine at all times.
- It cannot be assumed that every acceptable safety procedure is contained herein or that abnormal or unusual circumstances may not warrant or require future or additional procedures.

WORK SAFELY AT ALL TIMES!!!

4. GENERAL RECEIVING, HANDLING AND INSTALLATION

RECEIVING AND INSPECTION

Kice Industries, Inc., has prepared your new diverter valve for shipment in accordance with the Uniform Freight Classification. The valve has been thoroughly inspected at the factory and, barring damage in transit, should be in excellent condition upon arrival.

The diverter valve and accessories should be inspected upon receipt for any shipping damage. If actuators or position switches are provided, check these accessories for free operation of all moving parts.

When a carrier signs the Kice Industries, Inc., bill of lading, the **carrier accepts the responsibility** for any subsequent shortages or damage, evident or concealed, and **any claim must be made against the carrier by the purchaser**. Evident shortage or **damage should be noted on the carrier's delivery document** before signature of acceptance. Inspection by the carrier of damage, evident or concealed, must be requested. After inspection, issue a purchase order for necessary parts or arrange for return of the equipment to Kice Industries, Inc., for repair.

HANDLING AND STORAGE

Kice diverter valves are shipped in many different configurations. Some units are included with other equipment of the system, and some are completely assembled and skidded. These units may be handled and moved using good rigging techniques, being careful to avoid concentrated stresses that will distort any of the parts or guards.

If the diverter valve is not to be installed promptly, store it in a clean, dry location to prevent rust and corrosion of steel components. If outdoor storage is necessary, protection should be provided. Cover the inlet and outlets to prevent the accumulation of dirt and moisture inside the body. Cover the actuator and controls with waterproof material. Refer to the actuator maintenance information for further storage instructions.



Caution: Use proper equipment when lifting or moving the diverter valve. Make sure all persons and obstructions are clear from path and installation area.

INSTALLATION

1. Before installing the diverter valve, it is recommended that it be bench tested. Test the diverter valve by energizing the solenoids of the 4-way valve, or (in the case of an electric actuator) by switching on the current to the electric motor. Keep clear of the rotor, the pneumatic cylinder lever arm, and any pinch points. If any unusual noises occur, disconnect and lock out the power. Check the clearances between the diverter valve end plates and rotor (the rotor could have shifted to one side during shipment).



!!!WARNING!!! When testing the diverter valve, care MUST be taken to keep objects and body parts out of the valve. The rotor operates with tight clearances and will move fast with force!!!

Note: To prevent the connection between the actuator and the rotor from failing, the speed at which the diverter valve operates MUST be regulated by the flow control valves located on the exhaust ports of the 4-way valve.

2. Move the diverter valve to the installation area using proper equipment.

GENERAL RECEIVING, HANDLING AND INSTALLATION CONTINUED

3. The diverter valve must be adequately supported in such a way that its weight is not transferred to the tubing or piping connected to the inlet and outlets of the valve.
4. Compression couplings are normally used to connect the inlet and outlets of the diverter valve to the conveying line. Check the ends of the tubing or piping that will be connected to the diverter valve and make sure to clean any burrs and straighten any dents. Make sure the gap between the diverter valve and the tubing or piping is small (less than ¼ inch). When installing the couplings, check the coupling gaskets to make sure they do not protrude into the air stream.



REMEMBER: Couplings are used to seal the joing, not support the equipment.

5. Tighten all mounting fasteners securely. To insure proper operation, the diverter valve must be adequately supported and properly installed. All tubing or piping connected to the diverter valve should be independently supported, as excess weight may distort the diverter valve body and cause contact between moving parts. When installing outdoors, care must be taken to protect the controls from the weather.
6. If the diverter valve is air actuated, connect the high pressure air supply to the 4-way valve.
7. Connect the electrical control lines to the solenoids on the 4-way valve and to the position switches.
8. If equipped with an electric actuator, connect the electrical power lines and the control lines to the electric actuator and the position switches (there are no air connections with an electric actuator).



!!!WARNING!!! High voltage and rotating parts can cause serious or fatal injury. Only qualified personnel should perform installation, operation and maintenance of electrical machinery. Make sure that any electric motor and the frame of the diverter valve is effectively grounded in accordance with OSHA standards, the National Electrical Code and local codes.

9. Wiring from the controller to the solenoids should be #18 gauge.
10. Test the valve after installation by energizing the solenoids of the 4-way valve, or (in the case of an electric actuator) by switching on the current to the electric motor. Keep clear of the pneumatic cylinder lever arm and any pinch points. If any unusual noises occur, disconnect and lock out the power. Check the clearances between the diverter valve end plates and rotor (the rotor could have shifted to one side during installation).

NOTE: There is the possibility (especially with larger diverter valves) that, if a diverter valve is installed on its side (with the shaft pointing up), the weight of the rotor could cause the rotor to slip down against the lower end plate. If this occurs, contact a Kice representative. If specified at the time of order that the diverter valve would be installed in such a manner, a Teflon spacer could be inserted between the rotor and end plate to prevent the possibility of such a shift.

11. Reinstall any guards or covers removed during installation.
12. All Kice diverter valves have two 1/8" NPT ports in each end plate, either of which can be used for back pressure purging the void between the closed end rotor and the end plate. If the diverter valve is being used in an application that requires back pressure purge, remove one of the two plugs and connect plant air to each end plate. Adjust the air pressure with a regulator to at least 2 psig higher than the pressure inside the conveying line. The void can also be grease packed. If specified at the time of order, one of the 1/8" NPT openings will be fitted with a grease zerk and the void will be packed with

food grade lubricant before the diverter valve is shipped from the factory. The purge air or the grease pack is used to prevent the conveyed product from getting between the closed end rotor and the end plates of the diverter valve.

5. OPERATION AND START-UP PROCEDURE

The key to long and trouble free diverter valve operation is good maintenance practices. Periodically inspect the rotor for damage from foreign materials or wear. Inspect the bearings and the valve control system for excessive wear or loose connections.

A majority of the operating problems that occur with a diverter valve can be traced to improper adjustments and delayed, or neglected, maintenance. A consistently applied maintenance program will prevent many problems.

A thorough understanding of the diverter valve is a must if the operating problems are to be corrected satisfactorily. A good rule to follow when troubleshooting a problem is to never make more than one adjustment at a time, thereby isolating the problem by a process of elimination. The cause of a problem is usually simple and is easy to pinpoint if you systematically check each system and function.

MANUALLY OPERATED DIVERTER VALVES

1. Be certain that the manual operating lever will be readily accessible to the operator when changing the valve position. The operating lever travel must be unobstructed.
2. When the diverter valve installation is completed, check for satisfactory operation.

AIR ACTUATED DIVERTER VALVES

1. Check the limit switch adjustment. Switches should actuate whenever the rotor completes its travel. On diverter valves with rotary actuators, adjustments are made by removing the cover from the limit switch housing and rotating the cam corresponding to the switch requiring adjustment (see the limit switch instruction sheet for further details). On diverter valves with pneumatic cylinders, adjustments are made by repositioning the lever arm on the Allen-Bradley limit switch.

NOTE: Limit switches are used to indicate the position of the rotor, and often are used with indicator lights. They are in no way related to the function of the solenoid valve.

2. Wire the diverter valve up to the control panel. Note the voltage rating on the solenoid valve data plate.
3. Connect the diverter valve to the compressed air supply. Clean, dry, lubricated air at 100 psig is required for the 4-way valve and the actuator. The air lubricator should be no more than 10 feet from the actuator.
4. The purge air for the end plates of the diverter valve should be clean, dry and non-lubricated air.
5. When the diverter valve installation is completed, check for satisfactory operation and correct positioning. If the rotor does not position correctly, adjustment can be made by adjusting the travel stop located in the end cap of the rotary actuator, or by adjusting the jam nut and clevis on pneumatic cylinders. If positioning is opposite of what is desired, reverse the air lines on the actuator side on the solenoid valve. On rotary actuators, reverse the signal lines from the control panel to the solenoids. If panel lights do not indicate position correctly, reverse the limit switch wiring.

OPERATION AND START-UP PROCEDURE CONTINUED

MANUALLY OPERATED DIVERTER VALVES

1. When a change of diverter valve position is desired:
2. Pull the knurled knob to release the spring loaded, manually operated locking pin mounted on the operating lever.
3. Move the operating lever to the new position.
4. Release the spring loaded, manually operated knurled knob to engage the locking pin.

AIR ACTUATED DIVERTER VALVES

When a change of diverter valve position is desired:

Sequence of events for **DOUBLE** solenoid operated 4-way valve.

1. Select the desired diverter valve position on the control panel.
2. Push the button to close the contacts that energize the solenoid operated 4-way valve.
3. Hold the push button down until the position light comes on.
4. Release the push button. This will deactivate the solenoid on the 4-way valve.

Sequence of events for **SINGLE** solenoid operated 4-way valve.

1. Select the desired diverter valve position on the control panel.
2. Energize the single solenoid operated 4-way valve by closing a two-position switch. To keep the diverter valve in the required position, the solenoid valve must be energized continuously.
3. To return the diverter valve to the original position, de-energize the solenoid. The spring in the 4-way valve will return the air actuator to the starting position.

NOTE: In the event of an electrical power interruption or a solenoid failure, the diverter valve position can be changed as follows:

- a. First try using the red manual override buttons on the 4-way valve



IF THE AIR PRESSURE IS OFF, then –

- a. Disconnect the compressed air supply from the solenoid valve.
- b. Change the diverter valve position by manually moving the lever arm connecting the pneumatic cylinder to the diverter valve shaft.

6. DIVERTER VALVE MAINTENANCE AND SERVICE

LUBRICATION

1. The diverter valve bearings are permanently lubricated. Therefore, lubrication of the diverter valve is generally not required or recommended. Check the oil level in the lubricator bowl on the compressed air supply at regular intervals. **FILL AS REQUIRED!!!**
2. If the void between the rotor and the end plate is packed with grease, then one of the 1/8" NPT ports in the end plate will have a grease zerk while the other will be plugged. Once a year, remove the plug and pump some grease in through the grease zerk until excess grease is expelled through the open port.
3. Check the general condition of the diverter valve. Look for loose fasteners or signs of leakage.
4. Provide normal maintenance for the actuator, solenoid operated 4-way valve and positions switches.

DIVERTER VALVE MAINTENANCE AND SERVICE CONTINUED

- **Bearings for 67Qx-2 (two way valve):**

2 ea.	Link-Belt bearings:	67Q2-2 thru 67Q6-2	WB219
		67Q8-2	WB223
		67Q10-2 thru 67Q12-2	WB231

- **Bearings for 68Qx (bin fill valve):**

2 ea.	Link-Belt bearings:	68Q2 thru 68Q6	WB219
		68Q8	WB223

- **Bearings for 67Qx-3 (three way valve):**

2 ea.	Link-Belt bearings:	67Q2-3 thru 67Q6-3	WB219
		67Q8-3	WB223
		67Q10-3	WB231

- **Seals for 67Qx-2 (two way valve):**

2 ea.	Norman Technology seals:	67Q2-2 thru 67Q6-2	1154-3
		67Q8-2	1154-2
		67Q10-2 thru 67Q12-2	1154-1

- **Seals for 68Qx (bin fill valve):**

2 ea.	Norman Technology seals:	68Q2 thru 68Q6	1154-3
		68Q8	1154-2

- **Seals for 67Qx-3 (three way valve):**

2 ea.	Norman Technology seals:	67Q2-3 thru 67Q6-3	1154-3
		67Q8-3	1154-2
		67Q10-3	1154-1

- **Pneumatic Actuators for 67Qx-2 (two way valve):**

1 ea.	Sheffer pneumatic cylinder:	67Q2-2 thru 67Q4-2	2C20C2-1/2
		67Q5-2 and 67Q6-2	2-1/2C20C2-1/2
		67Q8-2 and 67Q10-2	3C20C4
		67Q12-2	4C20C4

OR

1 ea.	UniTorq rotary actuator	67Q2-2 thru 67Q4-2	M 74
		67Q5-2 and 67Q6-2	M 104
		67Q8-2	M 148
		67Q10-2 thru 67Q12-2	M 222

- **Pneumatic Actuators for 68Qx (bin fill valve):**

1 ea.	Sheffer pneumatic cylinder:	68Q2 thru 68Q4	2C20C5
		68Q5 and 68Q6	2-1/2C20C5
		68Q8	3C20C5

OR

1 ea.	UniTorq rotary actuator	68Q2 thru 68Q4	M 74
		68Q5 and 68Q6	M 104
		68Q8	M 148

- **Pneumatic Actuators for 67Qx-3 (three way valve):**

2 ea.	Sheffer pneumatic cylinder:	67Q2-3 thru 67Q6-3	2-1/2C20RF1-3/4
		67Q8-3	3C20RF2-3/4
		67Q10-3	4C20RF2-3/4

DIVERTER VALVE MAINTENANCE AND SERVICE CONTINUED

- **Position Switches for 67Qx-2 (two way valve) and 68Qx (bin fill valve):**

1 ea.	Allen-Bradley (used with Sheffer pneumatic cylinders) OR	all models	802T-NX116 (NEMA 4)
1 ea.	Allen-Bradley (used with Sheffer pneumatic cylinders) OR	all models	802X-NX2 (NEMA 7 & 9)
1 ea.	Moniteur (used with UniTorq rotary actuators) OR	all models	FFNB-E120 (NEMA 4)
1 ea.	Moniteur (used with UniTorq rotary actuators)	all models	AFNB-E120 (NEMA 7 & 9)

- **Position Switches for 67Qx-3 (three way valve):**

2 ea.	Allen-Bradley (used with Sheffer pneumatic cylinders) OR	all models	802T-NX116 (NEMA 4)
2 ea.	Allen-Bradley (used with Sheffer pneumatic cylinders)	all models	802X-NX2 (NEMA 7 & 9)

- **Double Solenoid Valves for 67Qx-2 (two way valve) and 68Qx (bin fill valve):**

1 ea.	Automatic Valve (used with Sheffer pneumatic cylinders) OR	all models	L0703ABWW-AA (NEMA 4)
1 ea.	Automatic Valve (used with Sheffer pneumatic cylinders) OR	all models	L0703ABYY-AA (NEMA 7 & 9)
1 ea.	Automatic Valve (used with UniTorq rotary actuators) OR	all models	B8022-188-9AA (NEMA 4)
1 ea.	Automatic Valve (used with UniTorq rotary actuators)	all models	B8022-188-391AA (NEMA 7 & 9)

- **Double Solenoid Valves for 67Qx-3 (three way valve):**

2 ea.	Automatic Valve (used with Sheffer pneumatic cylinders) OR	all models	L0703ABWW-AA (NEMA 4)
2 ea.	Automatic Valve (used with Sheffer pneumatic cylinders)	all models	L0703ABYY-AA (NEMA 7 & 9)

- **Single Solenoid Valves for 67Qx-2 (two way valve) and 68Qx (bin fill valve):**

1 ea.	Automatic Valve (used with Sheffer pneumatic cylinders) OR	all models	L0703AAWR-AA (NEMA 4)
1 ea.	Automatic Valve (used with Sheffer pneumatic cylinders) OR	all models	L0703AAYR-AA (NEMA 7 & 9)
1 ea.	Automatic Valve (used with UniTorq rotary actuators) OR	all models	B8016-114-AA (NEMA 4)
1 ea.	Automatic Valve (used with UniTorq rotary actuators)	all models	B8016-114-391AA (NEMA 7 & 9)

DIVERTER VALVE MAINTENANCE AND SERVICE CONTINUED

- **Single Solenoid Valves for 67Qx-3 (three way valve):**

2 ea.	Automatic Valve (used with Sheffer pneumatic cylinders)	all models	L0703AAWR-AA (NEMA 4)
	OR		
2 ea.	Automatic Valve (used with Sheffer pneumatic cylinders)	all models	L0703AAYR-AA (NEMA 7 & 9)

- **Electric Actuators for 67Qx-2 (two way valve):**

1 ea.	Bray electric actuator:	67Q2-2 thru 67Q4-2	S70-012
		67Q5-2 thru 67Q6-2	S70-020
		67Q8-2 thru 67Q12-2	S70-050

- **Electric Actuators for 68Qx (bin fill valve):**

1 ea.	Bray electric actuator:	68Q2 thru 68Q4	S70-012
		68Q5 thru 68Q6	S70-020
		68Q8	S70-050

- **Electric Actuators for 67Qx-3 (three way valve):**

1 ea.	Bray electric actuator:	67Q2-3 thru 67Q4-3	S70-012
		67Q5-3 thru 67Q6-3	S70-020
		67Q8-3 thru 67Q10-3	S70-050

7. TROUBLESHOOTING

MANUALLY OPERATED DIVERTER VALVE

PROBLEM/PROBABLE CAUSE	SUGGESTED REMEDIES
<ul style="list-style-type: none"> • Diverter valve position cannot be changed/ Material or debris is jammed inside the diverter valve, blocking the movement of the rotor 	<ol style="list-style-type: none"> 1. Remove the diverter valve from the conveying line. 2. Remove the lodged material or debris. 3. Check for damage to the diverter valve rotor or body.
<ul style="list-style-type: none"> • Diverter valve position cannot be changed/ Differential temperature between the interior and the exterior of the diverter valve is excessive (consult a Kice representative prior to performing this step). 	<ol style="list-style-type: none"> 1. Reduce the temperature of the conveying air. 2. Equalize the temperature between the interior and exterior of the diverter valve (insulate the body and/or heat trace the housing). 3. Remove the rotor and machine the rotor diameter to increase the internal clearances
<ul style="list-style-type: none"> • Diverter valve position cannot be changed/Rotor is rusted in place inside the diverter valve body 	<ol style="list-style-type: none"> 1. Disassemble the diverter valve and clean off the rust (take care during disassembly not to damage any parts). 2. Insulate the conveying line and the diverter valve body and/or heat trace the body to keep the temperature of the air inside the diverter valve above the dew point. 3. Move the rotor a minimum of once every 8 hours. 4. Chrome plate the interior of the body and nickel plate or epoxy coat the rotor (this should be performed at the factory so that the clearances can be adjusted to compensate for the thickness of the coating and/or the plating). 5. If the diverter valve end plates are back pressure purged, check the plant air for moisture.
<ul style="list-style-type: none"> • Diverter valve position cannot be changed/ Material is packed between the rotor and the end plates 	<ol style="list-style-type: none"> 1. Disassemble the diverter valve and clear the void of material (take care during disassembly not to damage any parts). 2. To prevent material from reforming in this area, food grade grease can be used as packing to prevent material from entering and binding the rotor. 3. Both ends of the rotor need to be cleaned and packed.

AIR ACTUATED DIVERTER VALVE

PROBLEM/PROBABLE CAUSE	SUGGESTED REMEDIES
<ul style="list-style-type: none"> Material leaks into the inactive leg of the diverter valve/Rotor position at each end of travel is incorrect. 	<ol style="list-style-type: none"> Check for proper setting of the flow control valves on the exhaust ports of the 4-way valve. They must be adjusted properly. If the pneumatic actuator is allowed to snap back and forth between the diverter valve positions too quickly, the inertia of the rotor can break the shaft coupling, shear the pin in the coupling and shaft, and break parts on the actuator travel stops.
<ul style="list-style-type: none"> Material leaks into the inactive leg of the diverter valve/Erosion has formed a path in the rotor or body for air and material to leak through 	<ol style="list-style-type: none"> Check for proper positioning of the rotor. Return the diverter valve to Kice Industries for repair or for an advanced replacement.
<ul style="list-style-type: none"> Diverter valve position cannot be changed/Air pressure is off, too low, or interrupted 	<ol style="list-style-type: none"> Check for pinched air line, cut air line, closed shutoff valve, clogged filter, faulty pressure regulator or defective compressor.
<ul style="list-style-type: none"> Diverter valve position cannot be changed/Control signal is not reaching the air control solenoid valve 	<ol style="list-style-type: none"> Check power supply to the panel. Check circuit continuity from the panel to the solenoid valve. Check the condition of position selector switch/push button.
<ul style="list-style-type: none"> Diverter valve position cannot be changed/Solenoid is not responding to control signal 	<ol style="list-style-type: none"> If the temperature is near or below freezing, check to see if moisture condensing in the compressed air supply line has frozen in the solenoid valve spool. Check the condition of the solenoid windings.
<ul style="list-style-type: none"> Diverter valve position cannot be changed/Air lines from the solenoid valve to the pneumatic actuator are blocked or disconnected 	<ol style="list-style-type: none"> Replace pinched, cut or missing lines.
<ul style="list-style-type: none"> Diverter valve position cannot be changed/Pneumatic actuator is inoperative 	<ol style="list-style-type: none"> Check for damage to the pneumatic actuator. If the diverter valve has been subjected to freezing temperatures, check for ice within the actuator that might be interfering with piston movement.
<ul style="list-style-type: none"> Diverter valve position cannot be changed/Moisture is causing the rotor to freeze or rust in place. 	<ol style="list-style-type: none"> Disassemble the diverter valve and clean off the rust (take care during disassembly not to damage any parts). Insulate the conveying line and the diverter valve body and/or heat trace the body to keep the temperature of the inside air above the dew point. Move the rotor a minimum of once every 8 hours. Chrome plate the interior of the body and nickel plate or epoxy coat the rotor (this should be done at the factory so that the clearances can be adjusted to compensate for the thickness of the coating and/or the plating). If the diverter valve end plates are back pressure purged, check the plant air for moisture.

TROUBLESHOOTING CONTINUED

<ul style="list-style-type: none">• Diverter valve position cannot be changed/ Material or debris is jammed inside the diverter valve, blocking the movement of the rotor	<ol style="list-style-type: none">1. Remove the diverter valve from the conveying line.2. Remove the lodged material or debris.3. Check for damage to the diverter valve rotor or body.
<ul style="list-style-type: none">• Diverter valve position cannot be changed/ Differential temperature between the interior and the exterior of the diverter valve is excessive	<ol style="list-style-type: none">1. Reduce the temperature of the conveying air.2. Equalize the temperature between the interior and exterior of the diverter valve (insulate the body and/or heat trace the housing).3. Remove the rotor and machine the rotor diameter to increase the internal clearances (consult a Kice representative prior to performing this step).
<ul style="list-style-type: none">• Diverter valve position cannot be changed/ Material is packed between the rotor and the end plates	<ol style="list-style-type: none">1. Disassemble the diverter valve and clear the void of material (take care during disassembly not to damage any parts).2. To prevent material from reforming in this area, food grade grease can be used as packing to prevent material from entering and binding the rotor.3. Both ends of the rotor need to be cleaned and packed.

8. ILLUSTRATED PARTS LIST

ILLUSTRATED PARTS FOR 67Qx-2 DIVERTER VALVE.....	20
DRAWING # DIV-5000	
ILLUSTRATED PARTS FOR 67Qx-3 DIVERTER VALVE.....	21
DRAWING # DIV-5001	
ILLUSTRATED PARTS FOR 68Qx BIN FILL VALVE.....	22
DRAWING # DIV-5002	

BILL OF MATERIAL				
ITEM	DESCRIPTION	MODEL	PART NO.	QTY.
A	BODY	-	-	1
B	ENDPLATE	-	-	2
C	ROTOR	-	-	1
D	NTI, DOUBLE LIP SEAL	67Q2-2 THRU 67Q6-2	NT11154-3	2
	NTI, DOUBLE LIP SEAL	67Q8-2	NT11154-2	
E	LINK BELT, SEALED BALL BEARING	67Q2-2 THRU 67Q6-2	WB219-EL	2
	LINK BELT, SEALED BALL BEARING	67Q8-2	WB223-EL	
F	LINK BELT, SHAFT COLLAR	-	-	2
	- SUPPLIED w/ BEARING			
	- LOCKS ROTOR IN PLACE			
G	TRANSITION	-	-	3
H	HHCS, 3/8"-16 x 3/4"	67Q2-2 THRU 67Q3-2	-	12
	HHCS, 3/8"-16 x 1"	67Q4-2 THRU 67Q6-2		24
	HHCS, 3/8"-16 x 1"	67Q8-2		
J	HHCS, 3/8"-16 x 1"	67Q2-2 THRU 67Q3-2	-	6
	HHCS, 3/8"-16 x 1 1/4"	67Q4-2 THRU 67Q6-2		12
	HHCS, 3/8"-16 x 1 1/4"	67Q8-2		

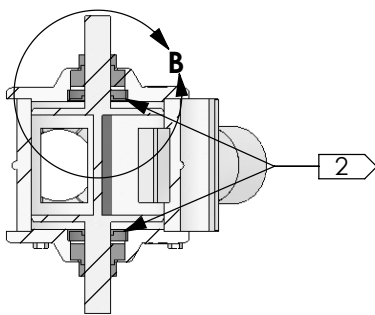
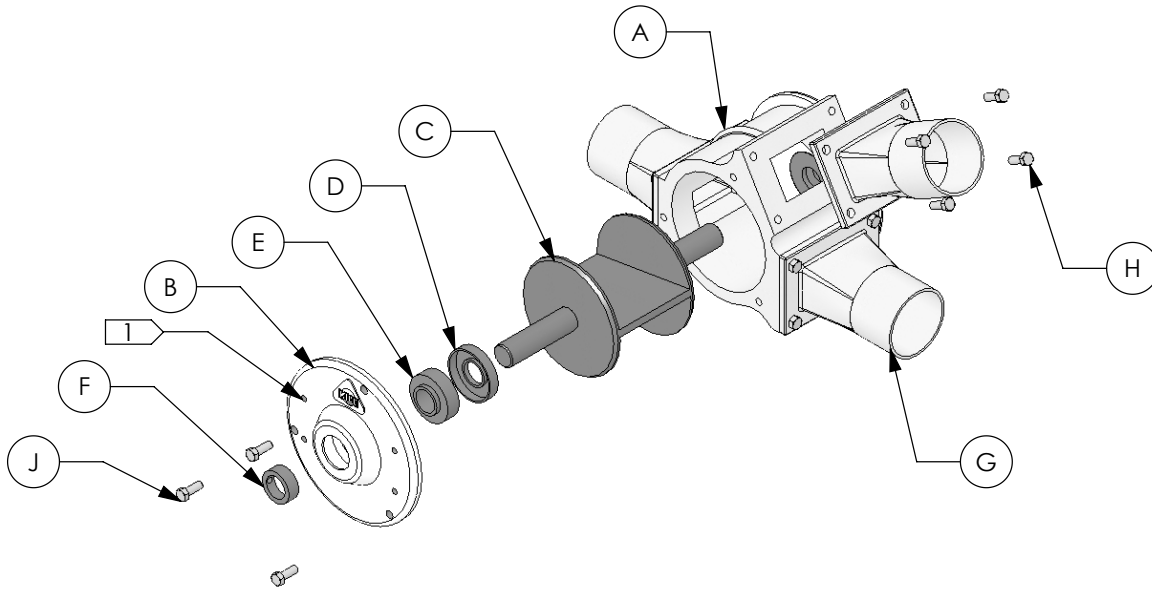

SECTION A-A

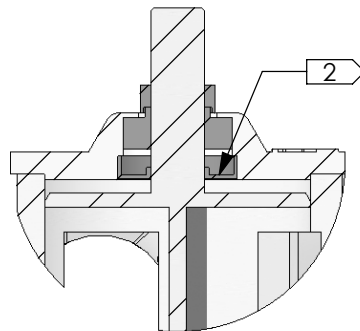

DETAIL B

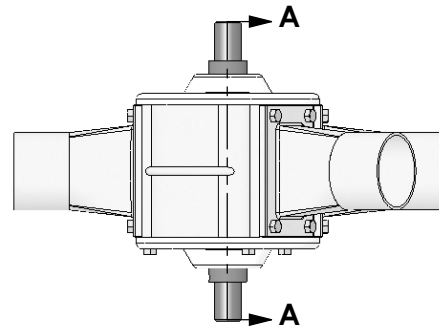

GEN. NOTES

- 1 (2 EA.) 1/8" NPT PORT w/ PLUG (CAN BE USED FOR BACK PRESSURE PURGE OR LUBE) SHIPPED DRY-NO LUBE UNLESS REQUESTED.
- 2 BEARING & SEAL ASSEMBLY TO BE THE SAME BOTH END PLATES.

67Qx-2 WAY
DIVERter VALVE
DESCRIPTION:



KICE INDUSTRIES, INC.

5500 MILL HEIGHTS DR. WICHITA, KANSAS 67219
PH: (316) 744-7151 FAX: (316) 744-7355

EJS 2/15/07 DIV-5000
DWN: DATE: DWG. NO.

BILL OF MATERIAL				
ITEM	DESCRIPTION	MODEL	PART NO.	QTY.
A	BODY	-	-	1
B	ENPLATE	-	-	2
C	ROTOR	-	-	1
D	NTI, DOUBLE LIP SEAL	67Q2-3 THRU 67Q6-3	NTI1154-3	2
	NTI, DOUBLE LIP SEAL	67Q8-3	NTI1154-2	
E	LINK BELT, SEALED BALL BEARING	67Q2-3 THRU 67Q6-3	WB219-EL	2
	LINK BELT, SEALED BALL BEARING	67Q8-3	WB223-EL	
F	LINK BELT, SHAFT COLLAR	-	-	2
	- SUPPLIED w/ BEARING			
	- LOCKS ROTOR IN PLACE			
G	TRANSITION	-	-	4
H	HHCS, 3/8"-16 x 3/4"	67Q2-3 THRU 67Q3-3	-	16
	HHCS, 3/8"-16 x 1"	67Q4-3 THRU 67Q6-3		32
	HHCS, 3/8"-16 x 1"	67Q8-3		
J	HHCS, 3/8"-16 x 1"	67Q2-3 THRU 67Q6-3	-	12
	HHCS, 3/8"-16 x 1 1/4"	67Q8-3		16

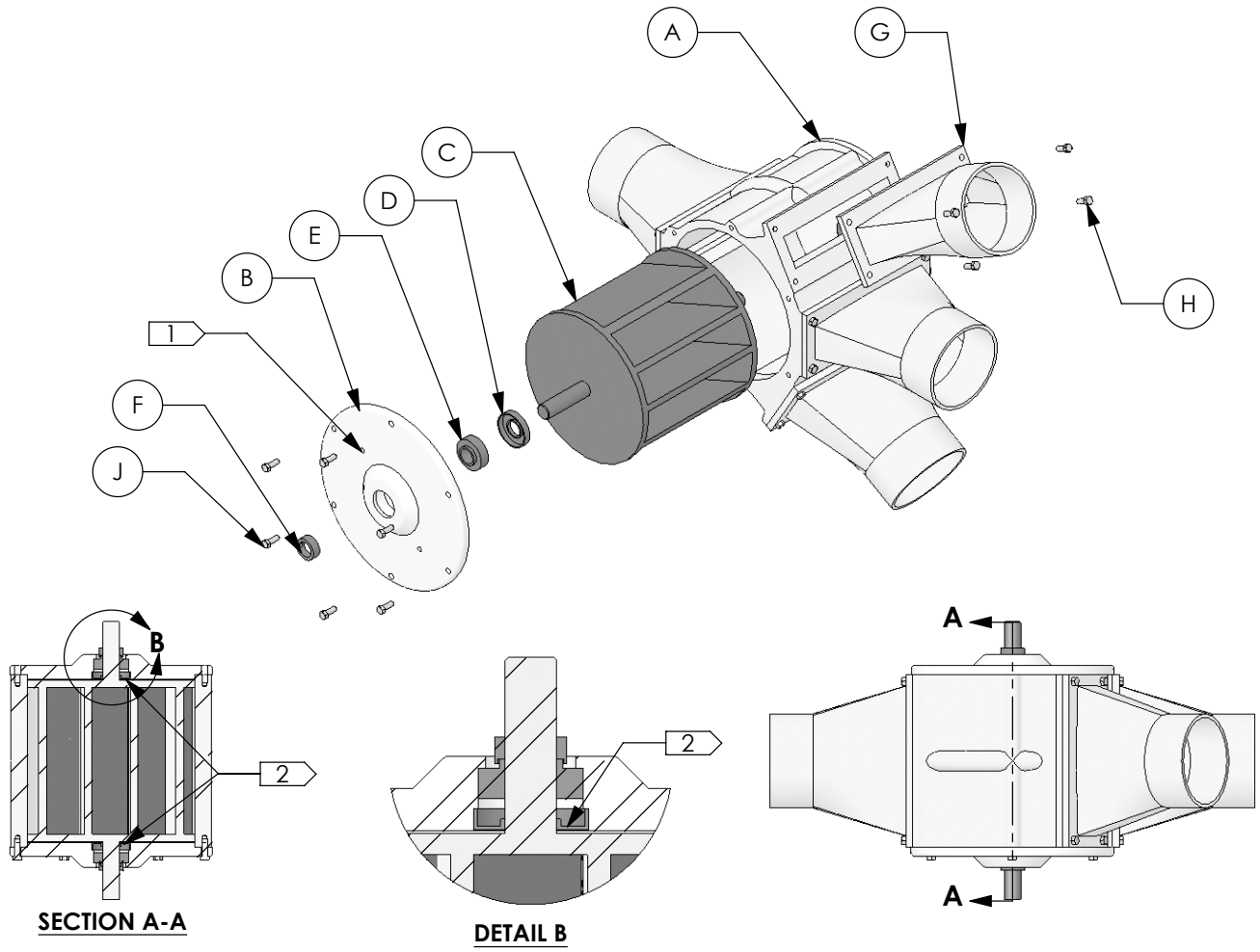

GEN. NOTES

1 (2 EA.) 1/8" NPT PORT w/ PLUG (CAN BE USED FOR BACK PRESSURE PURGE OR LUBE) SHIPPED DRY-NO LUBE UNLESS REQUESTED.

2 BEARING & SEAL ASSEMBLY TO BE THE SAME BOTH END PLATES.

67Qx-3
 DIVERTER VALVE
 DESCRIPTION:



KICE INDUSTRIES, INC.

5500 MILL HEIGHTS DR. WICHITA, KANSAS 67219
 PH: (316) 744-7151 FAX: (316) 744-7355

EJS 2/15/07 DIV-5001
 DWN: DATE: DWG. NO.

BILL OF MATERIAL				
ITEM	DESCRIPTION	MODEL	PART NO.	QTY.
A	BODY	-	-	1
B	ENPLATE	-	-	2
C	ROTOR	-	-	1
D	NTI, DOUBLE LIP SEAL	68Q2 THRU 68Q6	NTI1154-3	2
E	LINK BELT, SEALED BALL BEARING	68Q2 THRU 68Q6	WB219-EL	2
F	LINK BELT, SHAFT COLLAR	-	-	2
	- SUPPLIED w/ BEARING			
	- LOCKS ROTOR IN PLACE			
G	BAFFLE	-	-	1
H	HHCS, 3/8"-16 x 1"	68Q2 THRU 68Q6	-	6

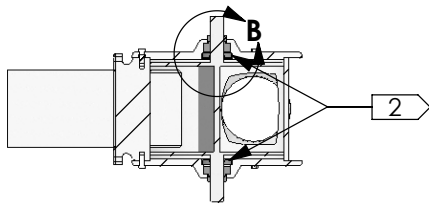
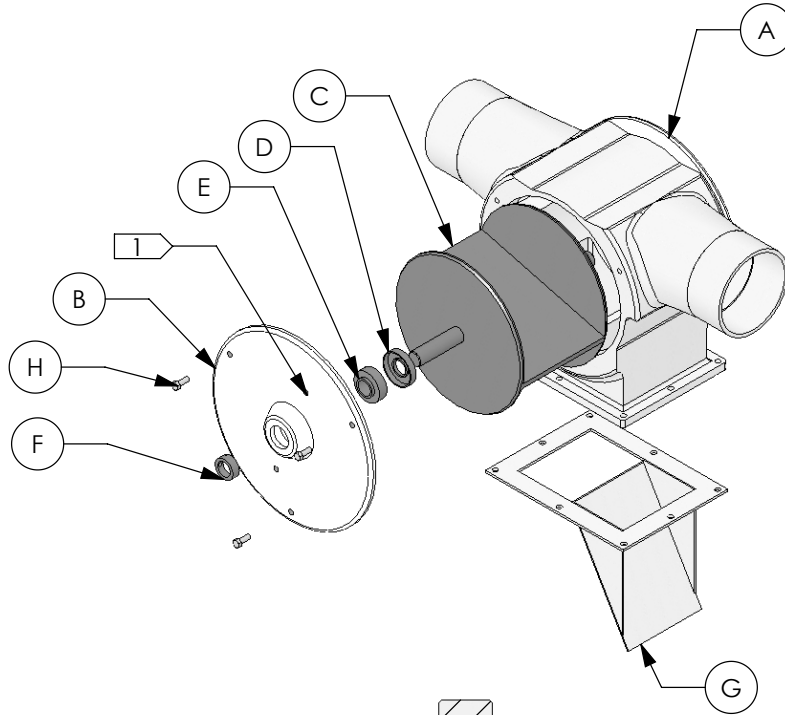

SECTION A-A

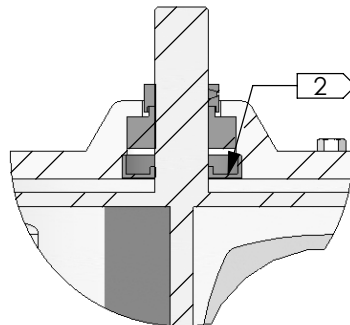

DETAIL B

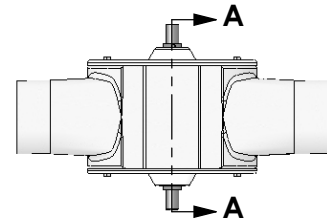

GEN. NOTES

- 1 (2 EA.) 1/8" NPT PORT w/ PLUG (CAN BE USED FOR BACK PRESSURE PURGE OR LUBE) SHIPPED DRY-NO LUBE UNLESS REQUESTED.
- 2 BEARING & SEAL ASSEMBLY TO BE THE SAME BOTH END PLATES.

68Qx
BIN FILL VALVE
DESCRIPTION:



KICE INDUSTRIES, INC.

5500 MILL HEIGHTS DR. WICHITA, KANSAS 67219
PH: (316) 744-7151 FAX: (316) 744- 7355

EJS
DWN:

2/15/07
DATE:

DIV-5002
DWG. NO.

9. WIRING SCHEMATICS

WIRING SCHEMATIC FOR 67QX-2 DIVERTER VALVE WITH ROTARY PNEUMATIC ACTUATOR	24
DRAWING DIV-5003	
WIRING SCHEMATIC FOR 67QX-2 DIVERTER VALVE WITH PNEUMATIC CYLINDER ACTUATOR	25
DRAWING DIV-5004	
WIRING SCHEMATIC FOR 68QX BIN FILL VALVE WITH ROTARY PNEUMATIC ACTUATOR	26
DRAWING DIV-5005	
WIRING SCHEMATIC FOR 68QX BIN FILL VALVE WITH PNEUMATIC CYLINDER ACTUATOR.....	27
DRAWING DIV-5006	
WIRING SCHEMATIC FOR 67QX-2 DIVERTER VALVE WITH ELECTRIC ROTARY ACTUATOR	28
DRAWING DIV-5007	
WIRING SCHEMATIC FOR 68QX BIN FILL VALVE WITH ELECTRIC ROTARY ACTUATOR	29
DRAWING DIV-5008	
WIRING SCHEMATIC FOR 67QX-3 DIVERTER VALVE WITH PNEUMATIC CYLINDER ACTUATOR.....	30
DRAWING DIV-5009	
WIRING SCHEMATIC FOR 67QX-3 DIVERTER VALVE WITH ELECTRIC ROTARY ACTUATOR.....	31
DRAWING DIV-5010	

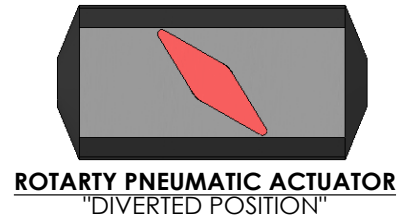
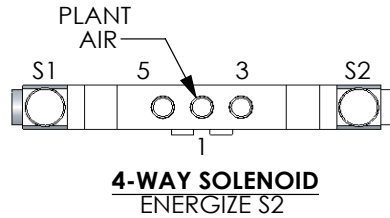
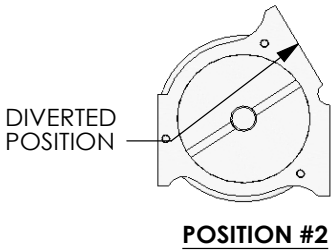
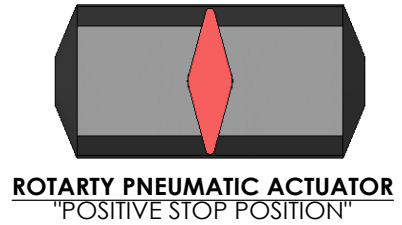
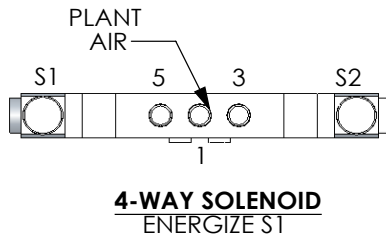
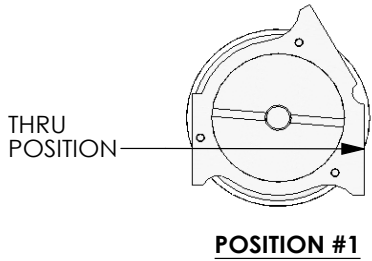

GEN. NOTES

1. USE CLEAN DRY PLANT AIR INTO 4-WAY (140PSIG MAX)
2. REF DWG. 1-3552 & 1-3305 FOR POSITION SWITCH.
3. ALL SWITCHES ARE INDIVIDUALLY CAM OPERATED & INFINITELY ADJUSTABLE.
4. SWITCHES ARE MOUNTED IN COMMON ENCLOSURE AVAILABLE IN NEMA 4 OR NEMA 7,9.
5. SWITCHES ARE UL & CSA LISTED 15A-125 OR 250 VAC: .5A-125 VOC: 25A-250 VOC
6. ALL WIRING SHOWN IN SCHEMATIC TO BE DONE BY OTHERS.

67Qx-2 WIRING
SCHEMATIC w/ ROTARY
PNEUMATIC ACTUATOR
DESCRIPTION:



KICE INDUSTRIES, INC.

5500 MILL HEIGHTS DR. WICHITA, KANSAS 67219
PH: (316) 744-7151 FAX: (316) 744-7355

EJS	2/15/07	DIV-5003
DWN:	DATE:	DWG. NO.

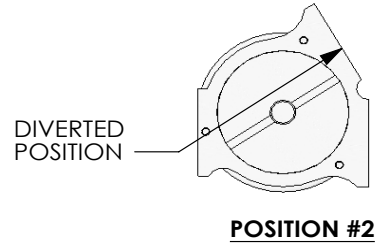
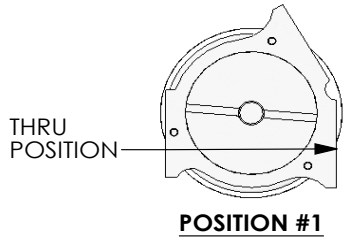

GEN. NOTES

1. ALL SWITCHES ARE INDIVIDUALLY CAM OPERATED & INFINITELY ADJUSTABLE.
2. SWITCHES ARE MOUNTED IN COMMON ENCLOSURE RATED AT NEMA 4, 4X & IP65.
3. SWITCHES ARE UL & CSA APPROVED: SPDT FORM 2, 10 AMP AT 125/250 VAC, 4 AMP AT 28 VDC INDUCTIVE LOAD, & 6 AMP AT 28 VDC RESISTIVE LOAD.
4. ALL WIRING SHOWN IN SCHEMATIC TO BE DONE BY OTHERS.

67Qx-2 WIRING
SCHEMATIC w/ ROTARY
ELECTRIC ACTUATOR

DESCRIPTION:



KICE INDUSTRIES, INC.

5500 MILL HEIGHTS DR. WICHITA, KANSAS 67219
PH: (316) 744-7151 FAX: (316) 744-7355

EJS
DWN:

2/16/07
DATE:

DIV-5004
DWG. NO.

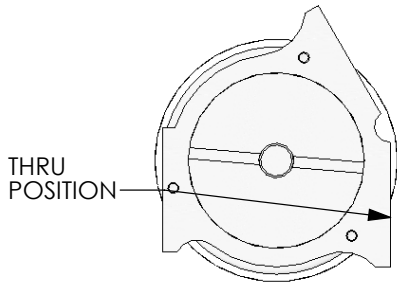

POSITION #1

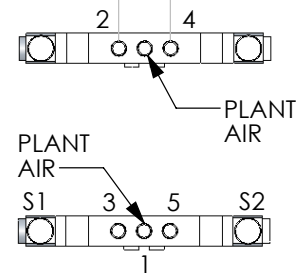
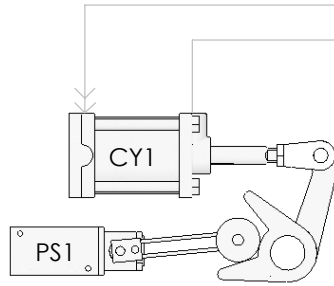

**4-WAY SOLENOID
ENERGIZE S1**

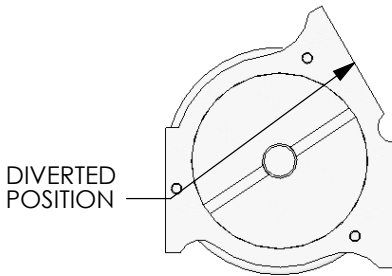

POSITION #2

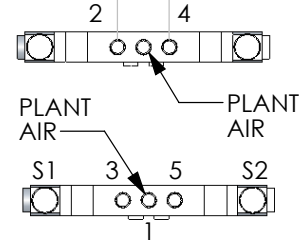
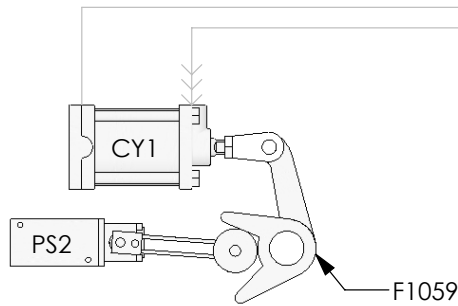

**4-WAY SOLENOID
ENERGIZE S2**

GEN. NOTES

1. USE CLEAN DRY AIR INTO 4-WAY VALVE (140PSIG MAX.)
2. SWITCH IS AVAILABLE IN NEMA 4, 7, & 9.
3. ALL WIRING SHOWN IN SCHEMATIC TO BE DONE BY OTHERS.

67Qx-2 WIRING
SCHEMATIC w/
AIR CYLINDER ACTUATOR
DESCRIPTION:



KICE INDUSTRIES, INC.

5500 MILL HEIGHTS DR. WICHITA, KANSAS 67219
PH: (316) 744-7151 FAX: (316) 744- 7355

EJS	2/16/07	DIV-5005
DWN:	DATE:	DWG. NO.

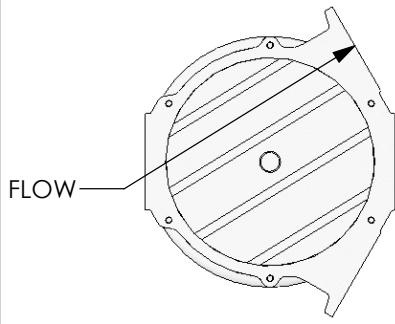

LEFT POSITION

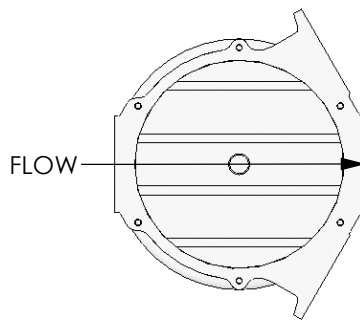

CENTER POSITION

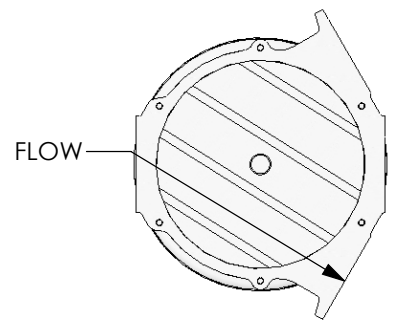

RIGHT POSITION

GEN. NOTES

1. SWITCHES ARE MOUNTED IN COMMON ENCLOSURE RATED AT NEMA 4,7 & 9/CSA ENCL. 4.
2. SWITCHES ARE CSA LISTED:
- SPOT, FORM C, 15AMP & 1/2 H.P., 12VAC, 10AMP, 250VAC
1/2AMP 125VOC, 1/4AMP 250VOC.
3. ALL SWITCHES ARE INDIVIDUALLY CAM OPERATED & INFINITELY ADJUSTABLE.
6. ALL WIRING SHOWN IN SCHEMATIC TO BE DONE BY OTHERS.

67Qx-3 WIRING
SCHEMATIC w/ ROTARY
ELECTRICAL ACTUATOR

DESCRIPTION:



KICE INDUSTRIES, INC.

5500 MILL HEIGHTS DR. WICHITA, KANSAS 67219
PH: (316) 744-7151 FAX: (316) 744- 7355

EJS
DWN:

2/15/07
DATE:

DIV-5006
DWG. NO.

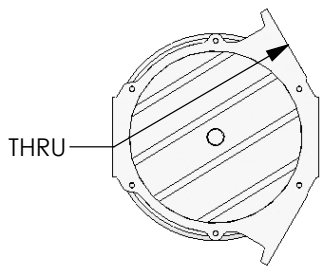

POSITION #1

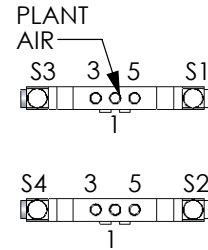
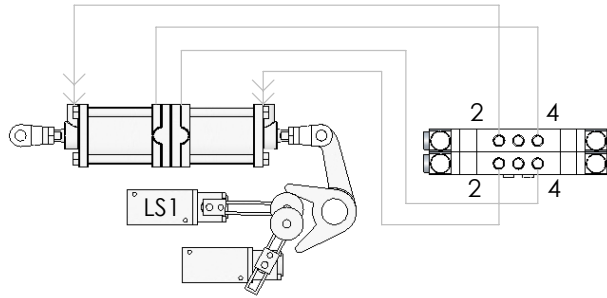

DOUBLE 4-WAY SOLENOID
ENERGIZE S1 & S2

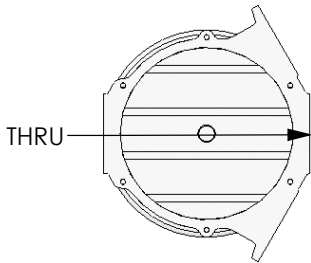

POSITION #2

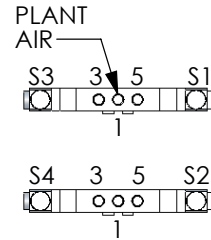
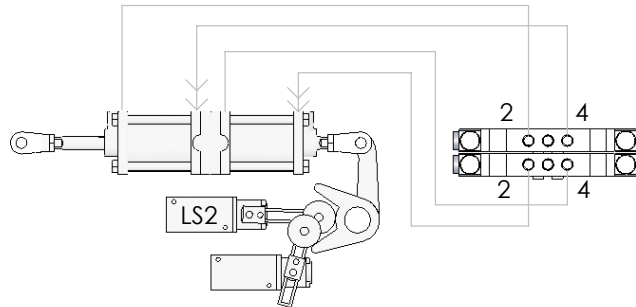

DOUBLE 4-WAY SOLENOID
ENERGIZE S2 & S3

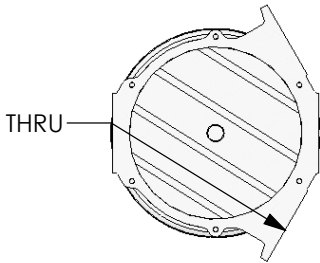

POSITION #3

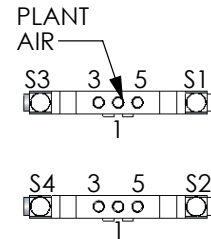
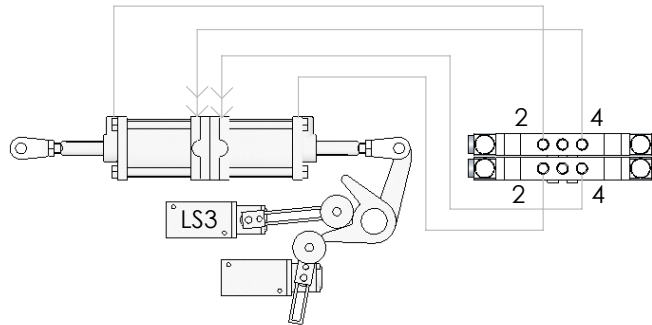

DOUBLE 4-WAY SOLENOID
ENERGIZE S3 & S4

GEN. NOTES

1. USE CLEAN DRY PLANT AIR INTO 4-WAY (140PSIG MAX)
2. SWITCH IS AVAILABLE IN NEMA/EEMAC 4 OR NEMA 7 & 9
3. ALL WIRING SHOWN IN SCHEMATIC TO BE DONE BY OTHERS.

67Qx-3 WIRING
SCHEMATIC w/
AIR CYLINDER ACTUATOR

DESCRIPTION:



KICE INDUSTRIES, INC.

5500 MILL HEIGHTS DR. WICHITA, KANSAS 67219
PH: (316) 744-7151 FAX: (316) 744-7355

EJS

DWN:

2/16/07

DATE:

DIV-5007

DWG. NO.

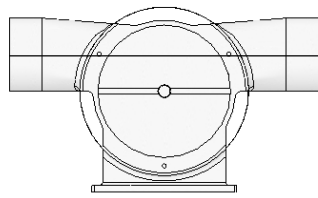

POSITION 1

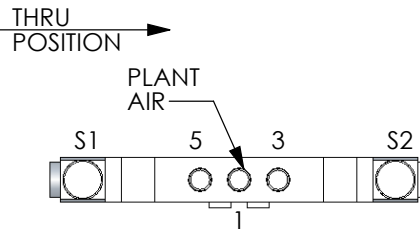

4-WAY SOLENOID
ENERGIZE S1

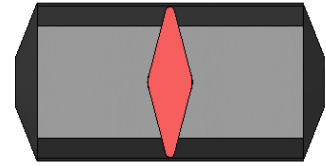

ROTARY PNEUMATIC ACTUATOR
"POSITIVE STOP POSITION"

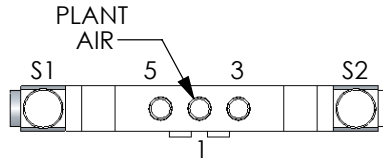

4-WAY SOLENOID
ENERGIZE S2

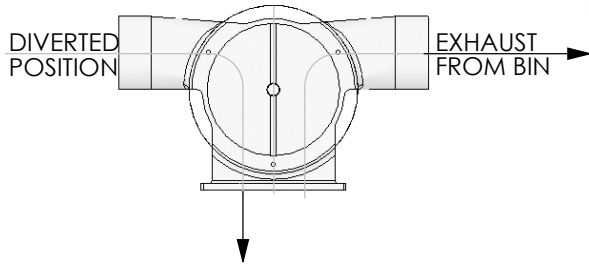

POSITION 2

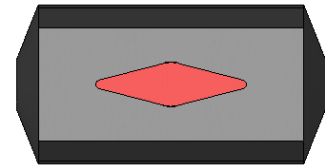

ROTARY PNEUMATIC ACTUATOR
"DIVERTED POSITION"

GEN. NOTES

1. USE CLEAN DRY PLANT AIR INTO 4-WAY (140PSIG MAX)
2. REF DWG. 1-3552 & 1-3305 FOR POSITION SWITCH.
3. ALL SWITCHES ARE INDIVIDUALLY CAM OPERATED & INFINITELY ADJUSTABLE.
4. SWITCHES ARE MOUNTED IN COMMON ENCLOSURE AVAILABLE IN NEMA 4 OR NEMA 7,9.
5. SWITCHES ARE UL & CSA LISTED 15A-125 OR 250 VAC: .5A 125 VOC: 25A-250 VOC
6. ALL WIRING SHOWN IN SCHEMATIC TO BE DONE BY OTHERS.

68Qx WIRING
SCHEMATIC w/ ROTARY
PNEUMATIC ACTUATOR
DESCRIPTION:



KICE INDUSTRIES, INC.

5500 MILL HEIGHTS DR. WICHITA, KANSAS 67219
PH: (316) 744-7151 FAX: (316) 744- 7355

EJS	2/16/07	DIV-5008
DWN:	DATE:	DWG. NO.

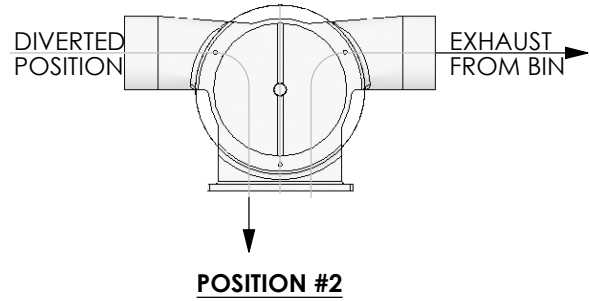
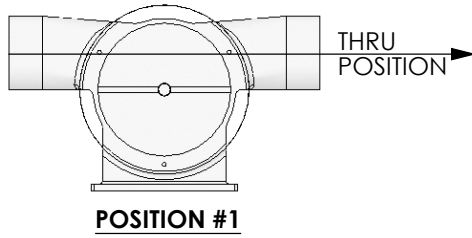

GEN. NOTES

1. SWITCHES ARE MOUNTED IN COMMON ENCLOSURE RATED AT NEMA 4, 7 & 9/CSA ENCL. 4.
2. SWITCHES ARE CSA LISTED:
- SPOT, FORM C, 15AMP & 1/2 H.P., 12VAC, 10AMP, 250VAC
1/2AMP 125VOC, 1/4AMP 250VOC.
3. ALL SWITCHES ARE INDIVIDUALLY CAM OPERATED & INFINITELY ADJUSTABLE.
6. ALL WIRING SHOWN IN SCHEMATIC TO BE DONE BY OTHERS.

68Qx WIRING
SCHEMATIC w/ ROTARY
ELECTRICAL ACTUATOR
DESCRIPTION:



KICE INDUSTRIES, INC.

5500 MILL HEIGHTS DR. WICHITA, KANSAS 67219
PH: (316) 744-7151 FAX: (316) 744-7355

EJS
DWN:

2/16/07
DATE:

DIV-5009
DWG. NO.

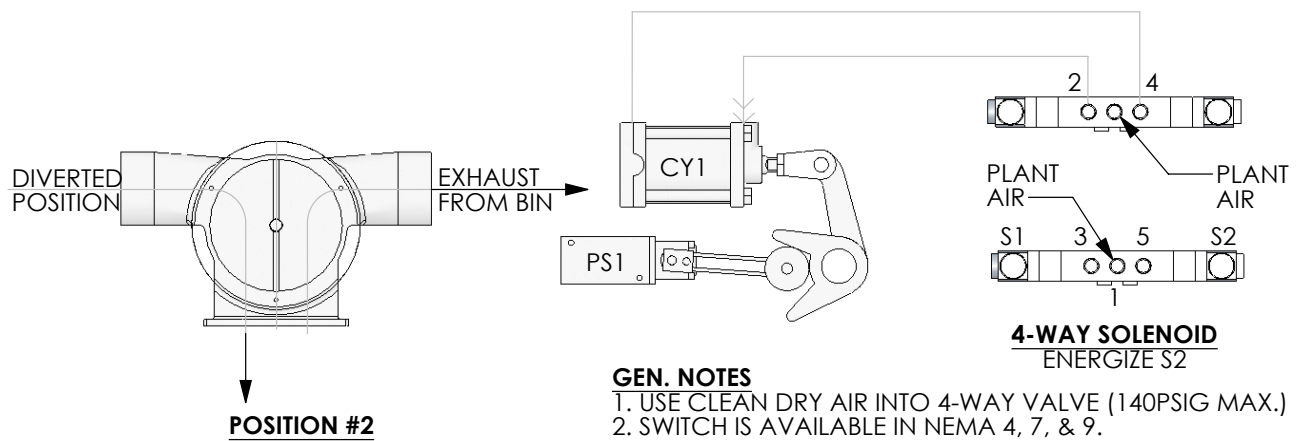
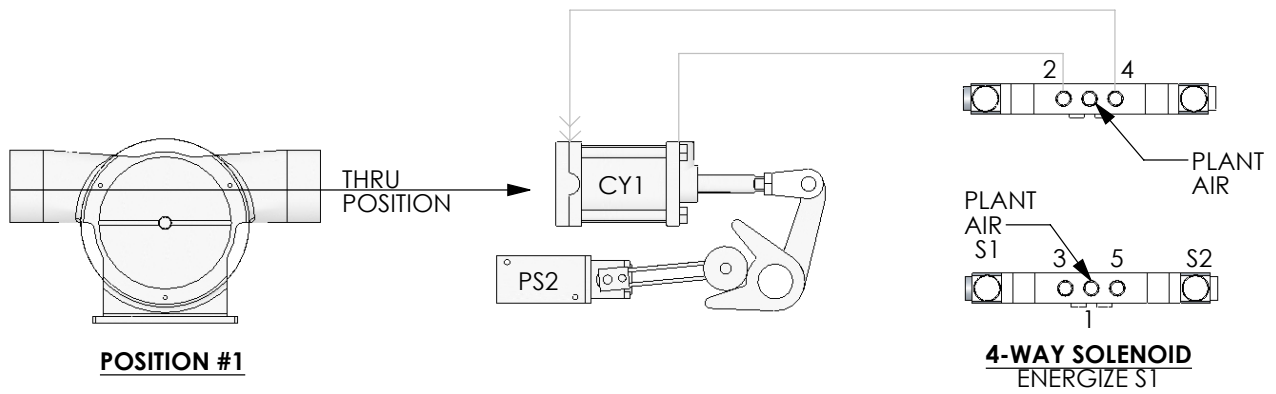

GEN. NOTES

1. USE CLEAN DRY AIR INTO 4-WAY VALVE (140PSIG MAX.)
2. SWITCH IS AVAILABLE IN NEMA 4, 7, & 9.
3. ALL WIRING SHOWN IN SCHEMATIC TO BE DONE BY OTHERS.

68Qx WIRING
SCHEMATIC w/
AIR CYLINDER ACTUATOR
DESCRIPTION:



KICE INDUSTRIES, INC.

5500 MILL HEIGHTS DR. WICHITA, KANSAS 67219
PH: (316) 744-7151 FAX: (316) 744-7355

EJS
DWN:

2/16/07
DATE:

DIV-5010
DWG. NO.

Kice Industries, Inc.
5500 Mill Heights Drive
Wichita, KS 67219



www.kice.com

P: 316-744-7151
F: 316-744-7355